

EAVZ-D6W

EAVZ-D9W

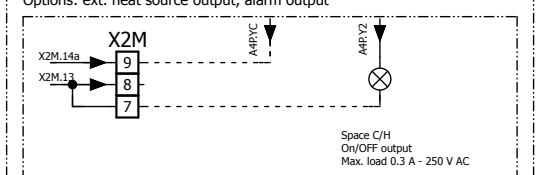
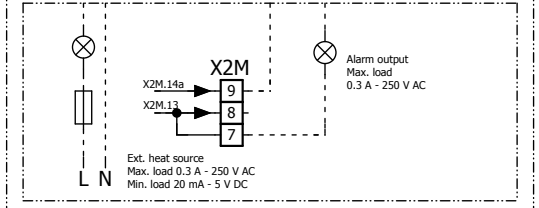
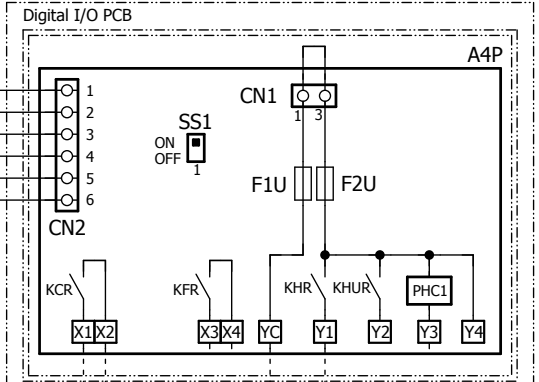
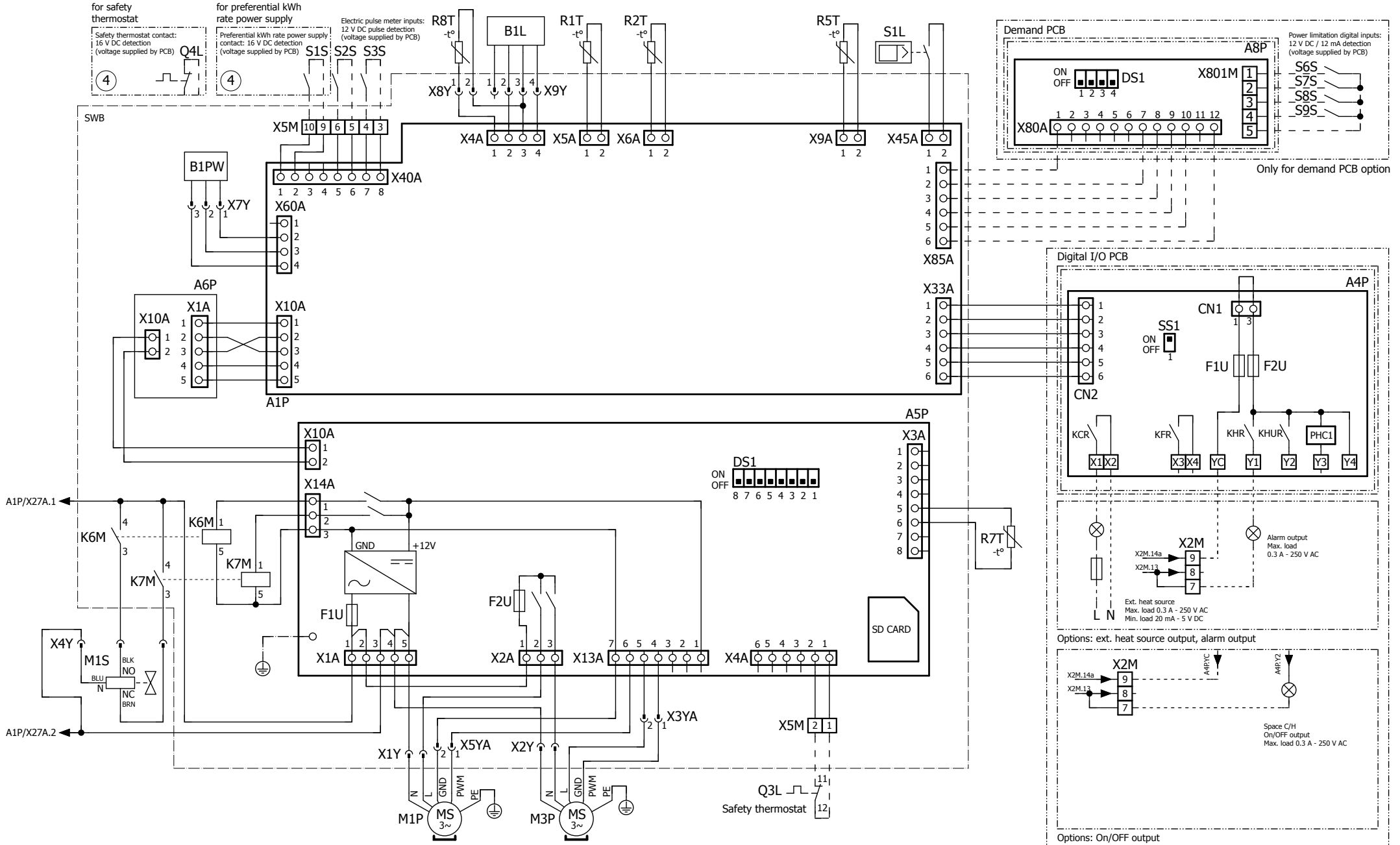

Options: On/Off output
Only for digital I/O PCB option