

EVLQ05CV3

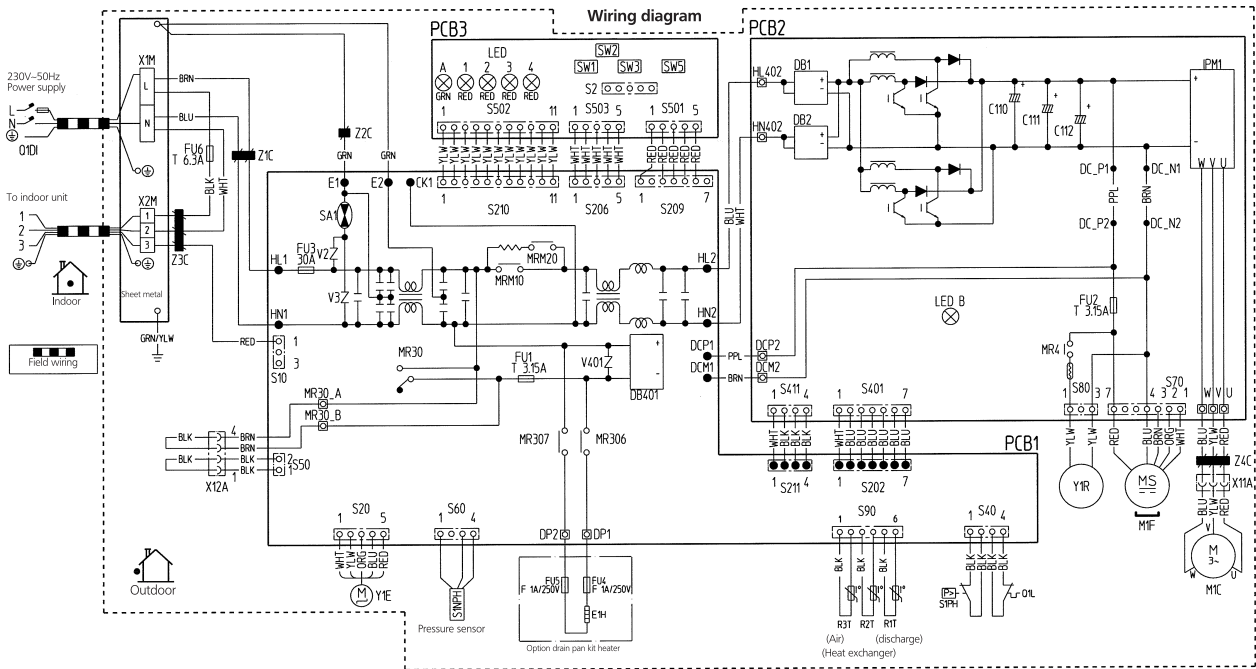

- | | | | |
|------------------------------|-----------------------------------|--------------------|-------------------------------|
| Z1C-Z4C | : Ferrite core | MR30, MRM10, MRM20 | : Magnetic relay |
| X1M, X2M | : Terminal stop | MR307, MR306, MR4 | : Thermistor (Heat exchanger) |
| Y1E | : Electronic expansion valve coil | R1T | : Thermistor (Discharge) |
| V2, V3, V401 | : Variator | R2T | : Thermistor (Heat exchanger) |
| SA1 | : Surge arrester | S2-S503 | : Connector |
| FU1, FU2, FU3, FU4, FU5, FU6 | : Fuse | SZ-5503 | : Pilot lamp |
| HL1, HN1, HL2, HN2 | | LED A, LED B | : Intelligent power module |
| LI, V, W, X11A, X12A | | PNV1 | : Live |
| E1, E2, DP1, DP2 | | L | : Neutral |
| DCP1, DCM1, DCP2, DCM2 | | N | : Push buttons |
| HL402, HN402, DC_P1, DC_N1 | | SW1, SW3 | : Dip switches |
| DC_P2, DC_N2, MR30_A, MR30_B | | SW2, SW5 | : Capacitor |
| E1H | : Connector | C110, C111, C112 | |
| STNH | : Drain pan heater | | |
| STPH | : Pressure sensor | | |
| | : Pressure sense | | |
| | : Pressure switch (high) | | |

- | | |
|-----------------|------------------------------------|
| PCB1 | : Printed circuit board (Main) |
| PCB2 | : Printed circuit board (Inverter) |
| PCB3 | : Printed circuit board (Service) |
| M1C | : Compressor motor |
| M1F | : Fan motor |
| M1F | : Indication lamps |
| L1-4 | : Overload protector |
| O1L | : Earth leakage circuit breaker |
| O1DI | : Rectifier bridge |
| DB1, DB2, DB401 | : Sheet metal |
| Y1R | : Reversing solenoid valve coil |
| Y1R | : Terminal stop fixed plate |

- Notes:
1. Refer to purchasing specification AS303002, unless otherwise specified.
 2. This drawing was drawn on CAD system.
 3. Size: length 140 x width 230.