

EVLQ08CV3

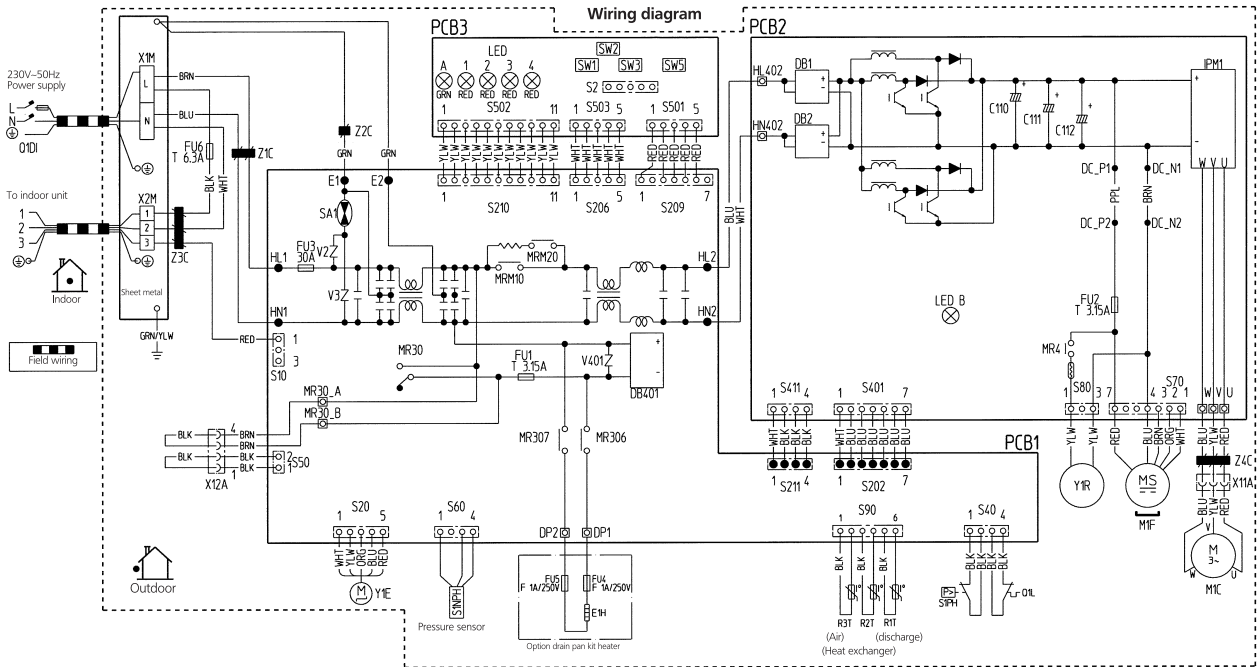

- Notes:
1. Refer to purchasing specification AS303002, unless otherwise specified.
 2. This drawing was drawn on CAD system.
 3. Size: length 140 x width 230.