

Y ditch  
Note 6

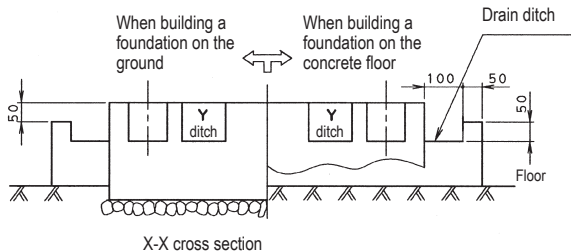

When building a  
foundation on the  
ground

When building a  
foundation on the  
concrete floor

Drain ditch

50

50

100

50

50

Floor

X-X cross section

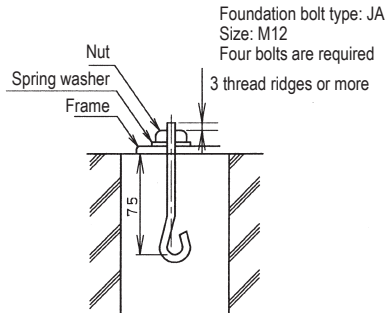

Foundation bolt executing method

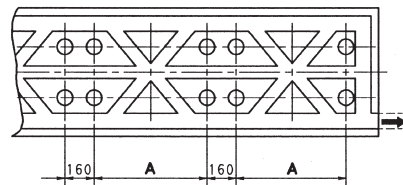

When installing multiple units in connection

Model	A	B
LRYEQ16AY1	1102	1302

## NOTES

1. The proportions of cement: sand: gravel for the concrete shall be 1:2:4, and the reinforcement bars that their diameter of 10mm, (approx. 300 mm intervals) shall be placed.
2. The surface shall be finished with mortar. The corner edges shall be chamfered.
3. When the foundation is built on a concrete floor, rubble is not necessary. However, the surface of the section on which the foundation is built shall have rough finish.
4. A drain ditch shall be made around the foundation to thoroughly drain water from the equipment installation area.
5. When installing the equipment on a roof, the floor strength shall be checked, and water-proofing measures shall be taken.