

RXYS8AY1

3N~, 50/60 Hz
380 - 415 V/400 V

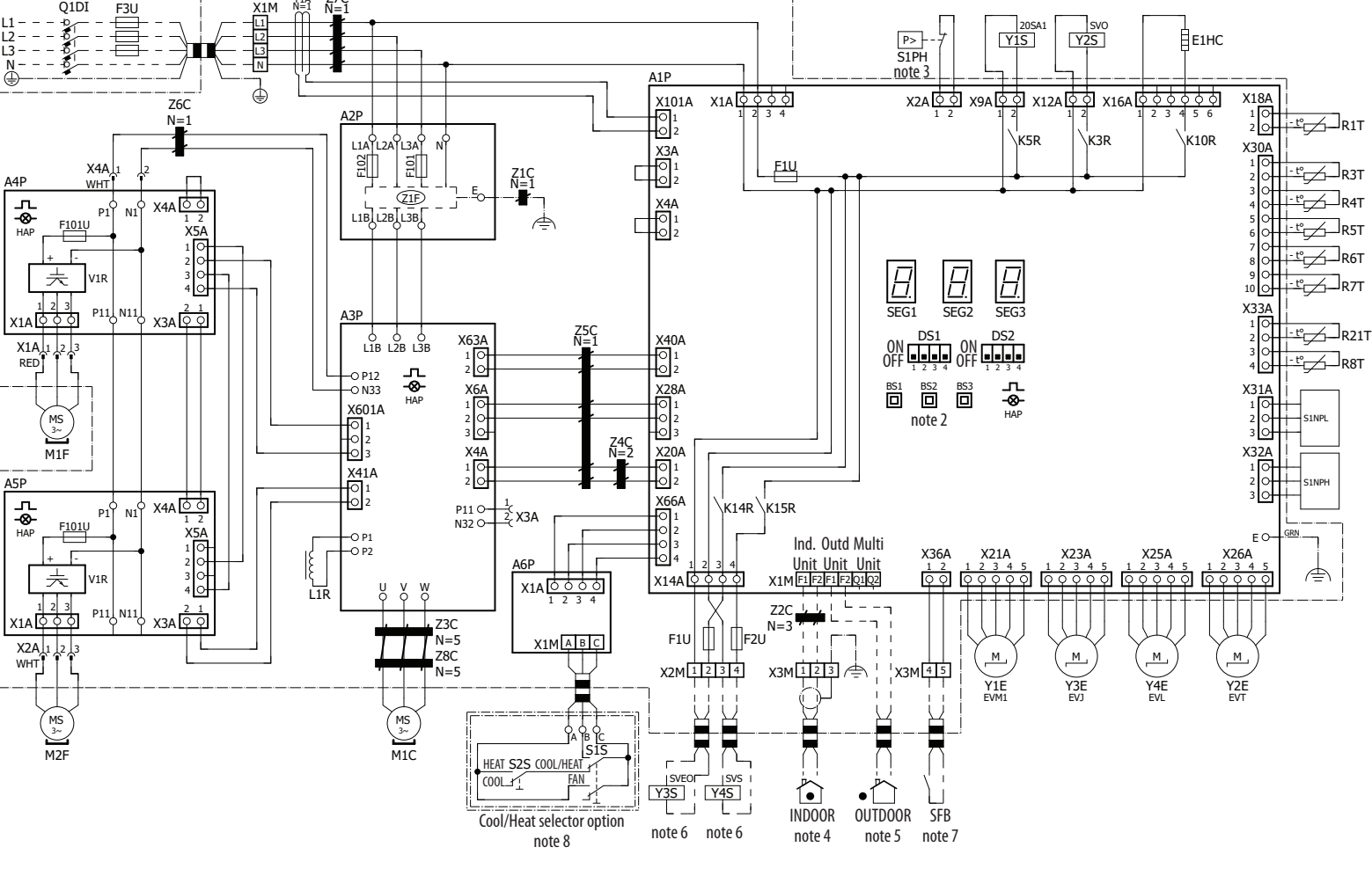

NOTES to go through before starting the unit

- Symbols:
 - X1M : Main terminal
 - : Earth wiring
 - - - : Field wire
 - ▬▬▬ : Field cable
 - ⊕ : Screened conductor
 - ① : Several wiring possibilities
 - [] : Option
 - [] : Wiring depending on model
 - [] : Not mounted in switch box
 - [] : PCB
- Refer to the installation or service manual on how to use BS1 ~ BS3 push buttons and DS1 ~ DS2 DIP switches.
- Do not operate the unit by short-circuiting protection device S1PH.
- Refer to the installation manual for indoor-outdoor transmission F1-F2 wiring.
- When using the central control system, connect outdoor-outdoor transmission F1-F2.
- The capacity of the contact is 220~240V AC - 0,5A (Rush current needs 3A or less).
- Use dry contact for micro-current (10mA or less, 15V DC).
- When using the optional adapter, refer to the installation manual of the optional adapter.

LEGEND

Part n°	Description	Part n°	Description
A1P	Printed circuit board (main)	R8T	Thermistor (M1C body)
A2P	Printed circuit board (noise filter)	R21T	Thermistor (M1C discharge pipe)
A3P	Printed circuit board (inverter)	S1NPH	High pressure sensor
A4P, A5P	Printed circuit board (fan)	S1NPL	Low pressure sensor
A6P	Printed circuit board (Cool/Heat Selector)	S1PH	High pressure switch
BS* (A1P)	Push button switch	S1S	* Air control switch
DS* (A1P)	Dipswitch	S2S	* Cool / Heat switch
E1HC	Crank case heater	SEG* (A1P)	7-segment display
F1U (A1P)	Fuse T 10 A 250 V	SFB	# Mechanical ventilation error input
F1U, F2U	Fuse T 1 A 250 V	T1A	Current sensor
F101U (A5P)	Fuse	V1R (A4P)	Power module
F101U (A4P)	Fuse	V1R (A5P)	Power module
F101 (A2P)	Fuse	X*A	Connector
F102 (A2P)	Fuse	X*M	Terminal strip
F3U	# Field fuse	Y1E	Electronic exp. valve (Heat exch.)
HAP (A*P)	Running LED (service monitor-green)	Y2E	Electronic exp. valve (Subc. heat exch.)
K*R (A*P)	Relay on PCB	Y3E	Electronic exp. valve (Inverter cooling)
L1R	Reactor	Y4E	Electronic exp. valve (Liquid injection)
M1C	Motor (compressor)	Y1S	Solenoid valve (4-Way valve)
M1F, M2F	Motor (fan)	Y2S	Solenoid valve (Accu oil return)
Q1DI	# Earth leakage circuit breaker	Y3S	# Error operation output (SVEO)
R1T	Thermistor (Air)	Y4S	# Leak sensor output (SVS)
R3T	Thermistor (Suction Accumulator)	Z*C	Noise filter (ferrite core)
R4T	Thermistor (Heat exch. liquid)	Z1F (A2P)	Noise filter (with surge absorber)
R5T	Thermistor (Liquid)		
R6T	Thermistor (Subcool heat exch. gas)		
R7T	Thermistor (De-icer)		

* : optional # : field supply

LAYOUT OF M1C, M1F, M2F

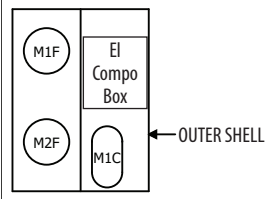

POSITION IN SWITCH BOX

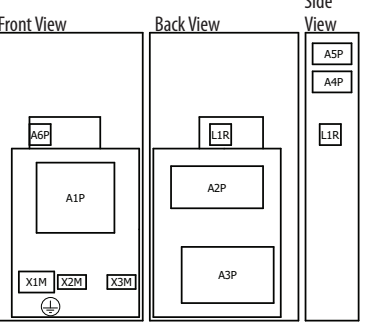

TERMINAL OF M1C

