

BR

Insulated Mixing Box

Description

Designed to collect and introduce both the return and bypass air back to the suction of the indoor unit. The device is supplied with stamped outlets (5 elliptical and 2 circular) and 3 elliptical side-fitting collars.

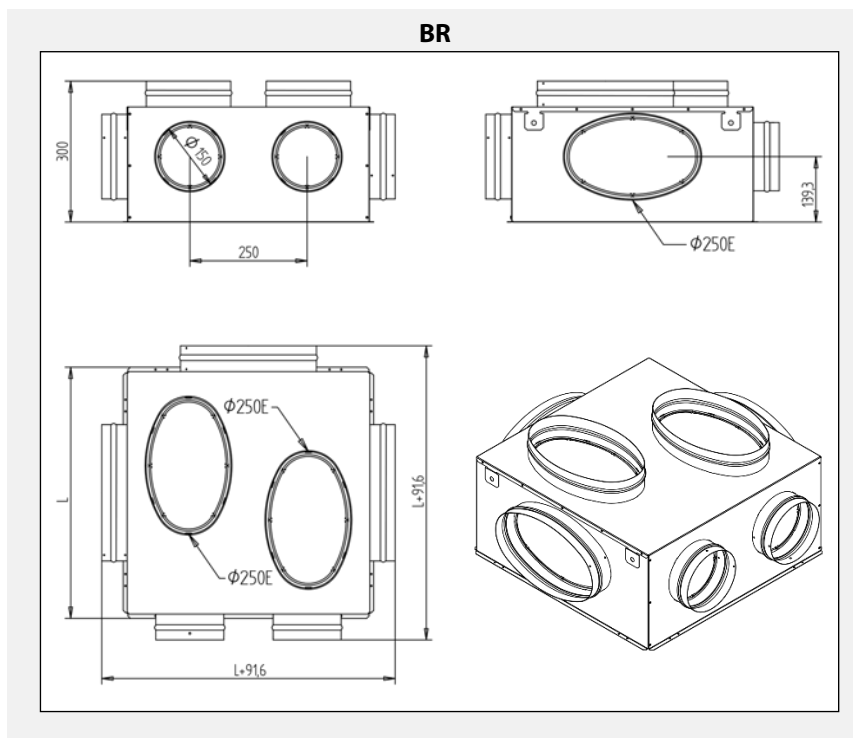

Note: The elliptical mouth (250E) is equivalent to the circular mouth of 250 mm in diameter.

Technical specs

Sizes	L: 400, 500 or 595 mm
Material	Galvanized sheet
Compatible accessories	Insulated flexible duct (TFTA) and non-insulated flexible duct (TFST)
Compatible grilles	RRFR (only for BR400 or BR500)

Collar assembly

1. Using a blade, cut the internal isolation of each outlet needed.
2. Remove the stamped area from the outlets.
3. Fix the collar by inserting the tabs on its matching slots.

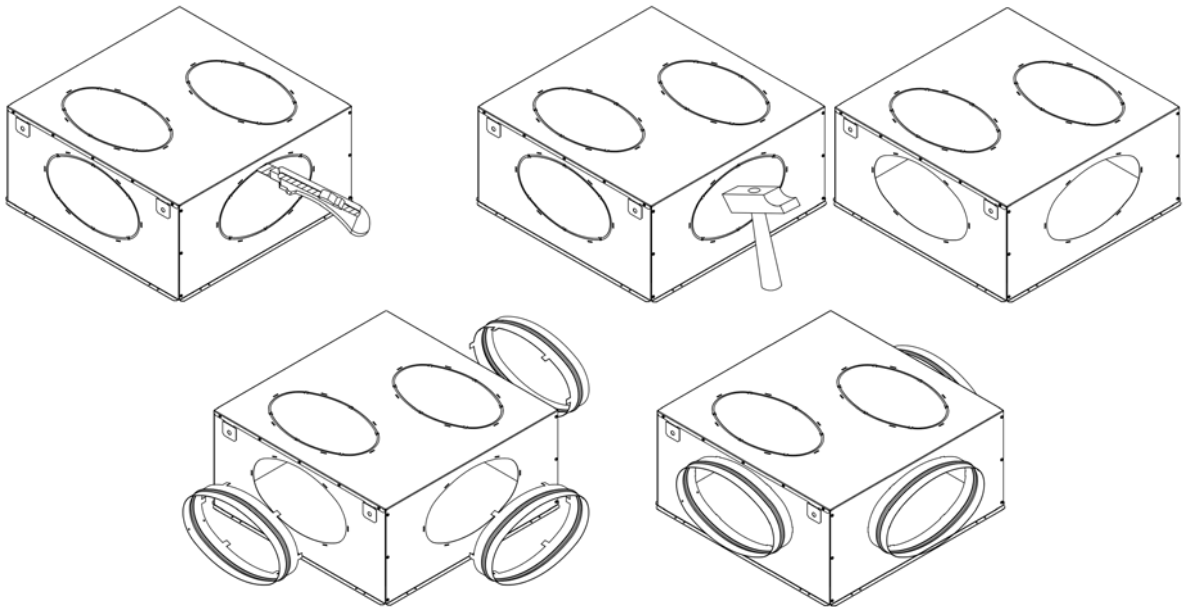

Ceiling fixation

The mixing box has 4 lugs for its fixing with threaded rods (flange 8).

Filter holder return grille assembly (RRFR)

The filter holder return grille assembly (RRFR), can only be mounted for BR 400 or 500 plenums.

The standard filter holder grille must be fixed using 4 Ø3,9x19 mm self-drilling countersunk screws.

Modular roof grilles are supported by the ceiling profiles. The mixing box is fixed using threaded rods and its height must be elevated until it matches with the grill.

